

ZMB431/ ZMB432 Precision Programmable Reference

1 Features

- Reference Voltage Tolerance at 25°C 0.5% (A Grade)
- Programmable Output Voltage to 36 V
- Low Dynamic Output Impedance 0.2 Ω
- Sink Current Capability of 0.5mA to 100mA
- Equivalent Full-Range Temperature Coefficient of 50ppm/°C Typical
- Temperature Compensated for Operation Over Full Rated Operating Temperature Range
- Low Output Noise Voltage
- Fast Turn on Response
- Operation Junction Temperature from -40°C to 150°C
- Lead-Free Packages: SOT23

2 Applications

- Adjustable Voltage and Current Referencing
- Power Supply
- Zener Replacement
- Voltage Monitoring
- Comparator with Integrated Reference
- As Precision Voltage Reference

3 Descriptions

The ZMB431 and ZMB432 device are three-terminal adjustable shunt regulators, with a guaranteed thermal stability over applicable temperature ranges. The output voltage can be set to any value between V_{REF} (approximately 2.5V) and 36V with two external resistors. These devices have provided a very sharp turn-on characteristic, making these devices excellent replacement for Zener diodes in many applications.

Both the ZMB431 and ZMB432 devices are offered in one grade, with initial tolerances (at 25°C) of 0.5% .

Device Information (1)

PART NUMBER	PACKAGE(PIN)	BODY SIZE (NOM)
ZMB431	SOT23(3)	1.30mm×2.92mm
ZMB432	SOT23(3)	1.30mm×2.92mm

(1) For more detail information packages, see the order sheet.

4 Function Block Diagram

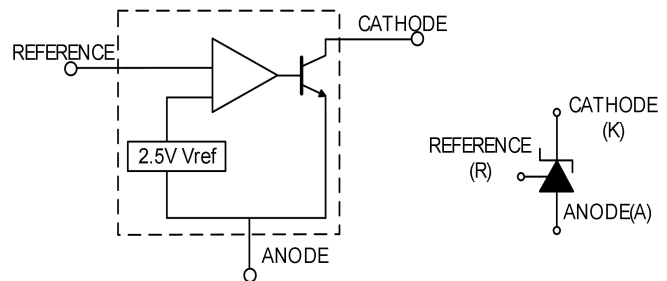

Table of Contents

1 Features 1

2 Applications 1

3 Descriptions 1

4 Function Block Diagram 1

5 Revision History 3

6 Package/Ordering Information 4

7 Pin configuration and Functions 5

8 Specifications 6

 8.1 Absolute Maximum Ratings 6

 8.2 ESD Ratings 6

 8.3 Recommended Operating Conditions 6

 8.4 Electrical Characteristics 7

 8.5 Typical Applications Circuit 8

 8.6 Typical Performance Characteristics 9

9 Package Outline Dimensions 11

10 Tape and Reel Information 12

5 Revision History

Note: Page numbers for previous revisions may differ from page numbers in the current version.

Version	Change Date	Change Item
A.1	2018/11/03	Initial version completed

6 Package/Ordering Information ⁽¹⁾

PRODUCT	ORDERING NUMBER	VOLTAGE TOLERANCE	PACKAGE LEAD	PACKAGE MARKING ⁽²⁾	MSL ⁽³⁾	PACKAGE OPTION
ZMB431	ZMB431AYSF3	0.5%	SOT23	431A XXXXX	MSL3	Tape and Reel,3000
ZMB432	ZMB432AYSF3	0.5%	SOT23	432A XXXXX	MSL3	Tape and Reel,3000

NOTE:

- (1) This information is the most current data available for the designated devices. This data is subject to change without notice and revision of this document. For browser-based versions of this data sheet, refer to the right-hand navigation.
- (2) Package marking:
Line1: Product model
Line2: Internal code(1-bit) + date code (3-bit) +1-bit LOT code
- (3) MSL, The Moisture Sensitivity Level rating according to the JEDEC industry standard classifications.

7 Pin configuration and Functions (Top View)

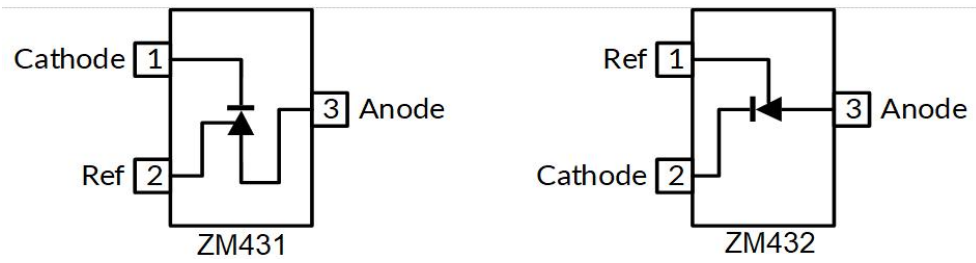

Pin Description

NAME	PIN		DESCRIPTION
	ZMB431	ZMB432	
Cathode	1	2	Shunt Current/ Voltage input
Ref	2	1	Threshold relative to common anode
Anode	3	3	Common pin, normally connected to ground

8 specifications

8.1 Absolute Maximum Ratings

over operating free-air temperature range (unless otherwise noted) ⁽¹⁾⁽²⁾

Characteristics	Symbol	MIN	MAX	UNIT
Cathode Voltage	V_{KA}	-0.3	37	V
Cathode Current Range (Continuous)	I_{KA}	-100	+155	mA
Reference Input Current Range	I_{REF}	-0.05	+10	mA
Operating junction temperature	T_{opr}	-40	+150	°C
Package thermal impedance ⁽³⁾	SOT23 θ_{JA}		295	°C/W
Power Dissipation	P_D	370		mW
Storage temperature	T_{stg}	-55	150	°C

- (1) Stresses beyond those listed under Absolute Maximum Ratings may cause permanent damage to the device. These are stress ratings only, and functional operation of the device at these or any other conditions beyond those indicated under Recommended Operating Conditions is not implied. Exposure to absolute-maximum-rated conditions for extended periods may affect device reliability.
- (2) All voltages are with respect to the GND pin.
- (3) The package thermal impedance is calculated in accordance with JESD-51.

8.2 ESD Ratings

The following ESD information is provided for handling of ESD-sensitive devices in an ESD protected area only.

			VALUE	UNIT
$V_{(ESD)}$	Electrostatic discharge	Human-Body Model (HBM), per ANSI/ESDA/JEDEC JS-001 ⁽¹⁾	±4000	V
		Charge Device Model (CDM), per ANSI/ESDA/JEDEC JS-002 ⁽²⁾	±1000	V
		Machine Model (MM)	±200	V

- (1) JEDEC document JEP155 states that 500 V HBM allows safe manufacturing with a standard ESD control process.
- (2) JEDEC document JEP157 states that 250 V CDM allows safe manufacturing with a standard ESD control process.



ESD SENSITIVITY CAUTION

ESD damage can range from subtle performance degradation to complete device failure. Precision integrated circuits may be more susceptible to damage because very small parametric changes could cause the device not to meet its published specifications.

8.3 Recommended Operating Conditions

over operating free-air temperature range (unless otherwise noted)

Characteristics	Symbol	MIN	MAX	UNIT
Cathode Voltage	V_{KA}	V_{REF}	36	V
Cathode Current Range (Continuous)	I_{KA}	0.5	100	mA
Operating Ambient Temperature Range	T_A	-40	+125	°C

8.4 Electrical Characteristics

(Over recommended operating conditions, Full= -40°C to +125°C, typical values are at T_A= +25°C, unless otherwise noted.)

PARAMETER	SYMBOL	CONDITIONS		MIN	TYP	MAX	UNIT
Reference Input Voltage	V _{REF}	V _{KA} =V _{REF} , I _{KA} =10mA	0.5%	2.488	2.50	2.512	V
Deviation of reference Input Voltage Over temperature	ΔV _{REF}	V _{KA} =V _{REF} , I _{KA} =10mA T _A = -40°C ~ +125°C		-	20	60	mV
Ratio of Change in Reference Input Voltage to the Change in Cathode Voltage	ΔV _{REF} /ΔV _{KA}	I _{KA} =10mA	ΔV _{KA} =10V~V _{REF}	-	-1.2	-2.0	mV/V
			ΔV _{KA} =36V~10V	-	-1.5	-2.0	
Reference Input Current	I _{REF}	I _{KA} =10mA, R1=10kΩ, R2=∞		-	1.7	4.0	uA
Deviation of Reference Input Current Over Full Temperature Range	ΔI _{REF}	I _{KA} =10mA, R1=10kΩ, R2=∞ T _A = -40°C ~ +125°C		-	2	5	uA
Minimum cathode current for regulation	I _{KA} (min)	V _{KA} =V _{REF}		-	0.3	0.5	mA
Off-state Cathode Current	I _{KA} (OFF)	V _{KA} =36V, V _{REF} =0V		-	0.05	0.5	uA
Dynamic Impedance	Z _{KA}	V _{KA} =V _{REF} , I _{KA} =1mA to100mA f≤1.0KHz		-	0.2	0.5	Ω

8.5 Typical Applications Circuit

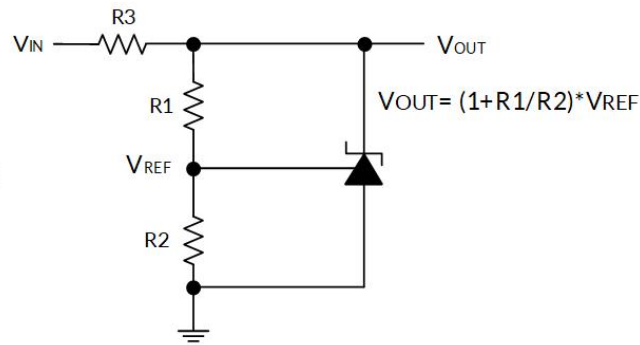

Figure 1. Shunt Regulator

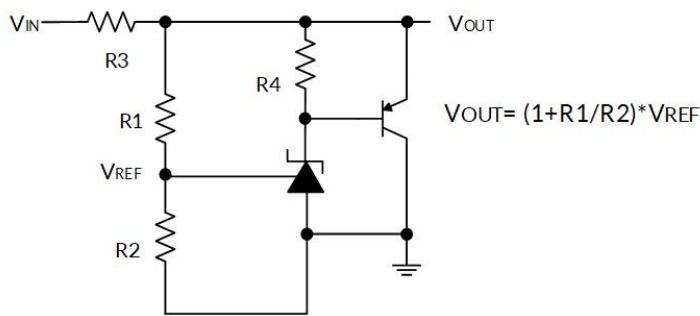

Figure 2. High Current Shunt Regulator

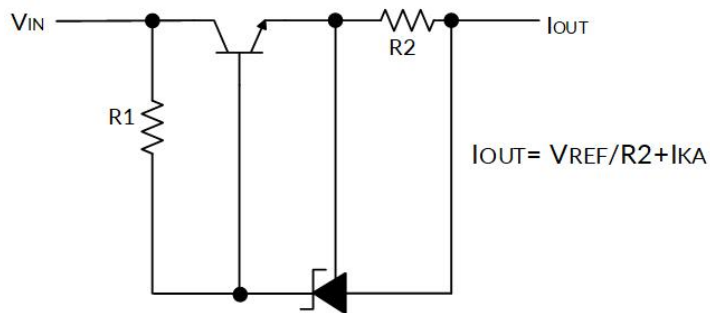

Figure 3. Current Source or Current Limit

8.6 Typical Performance Characteristics

NOTE: The graphs and tables provided following this note are a statistical summary based on a limited number of samples and are provided for informational purposes only.

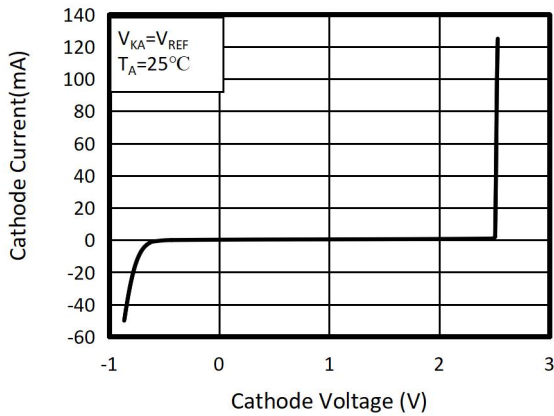

Figure 4. Cathode Current vs Cathode Voltage

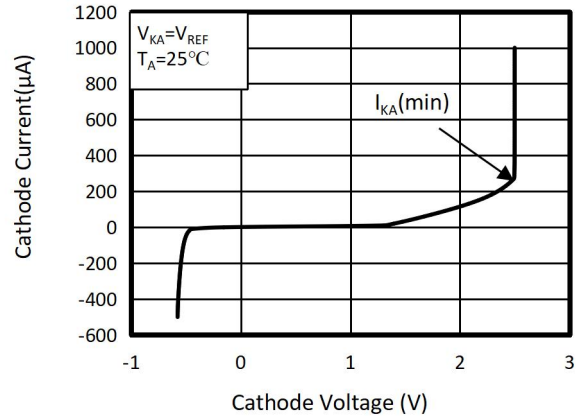

Figure 5. Cathode Current vs Cathode Voltage

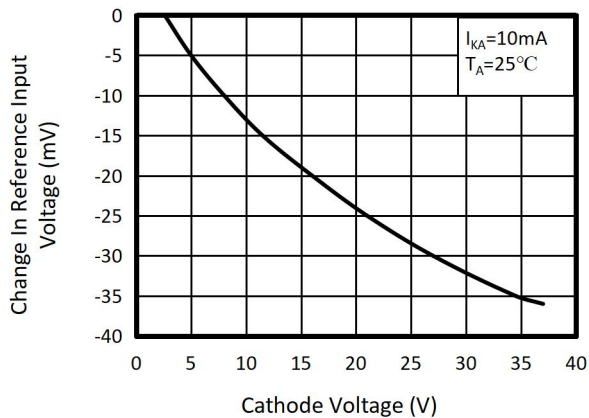

Figure 6. Change in Reference Input Voltage vs Cathode voltage

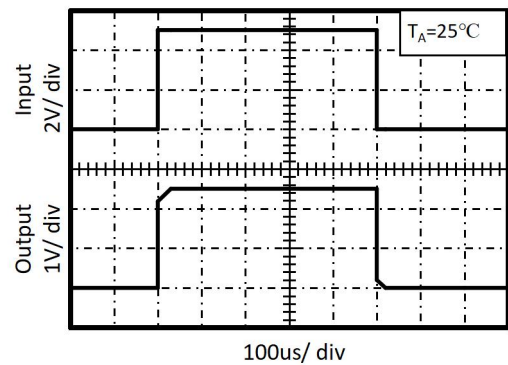

Figure 7. Pulse Response

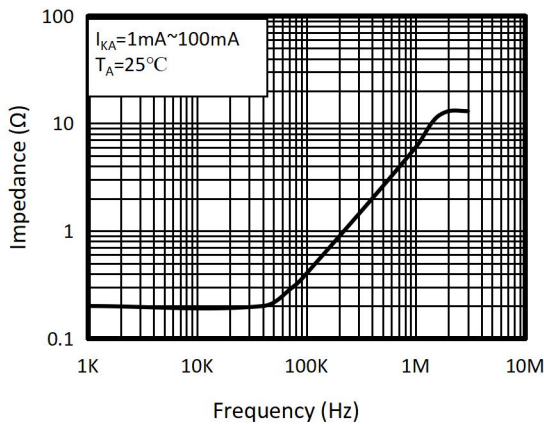

Figure 8. Dynamic Impedance vs Frequency

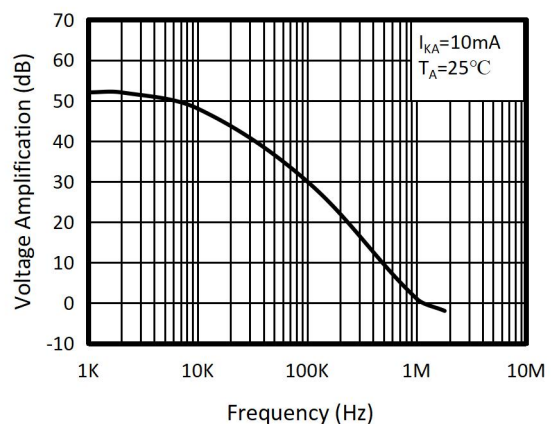

Figure 9. Small Signal Voltage Amplification vs Frequency

Typical Performance Characteristics (Continued)

NOTE: The graphs and tables provided following this note are a statistical summary based on a limited number of samples and are provided for informational purposes only.

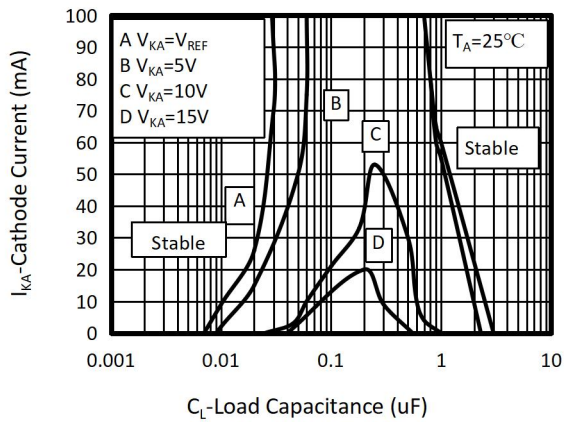

Figure 10. Cathode Current vs Load Capacitance

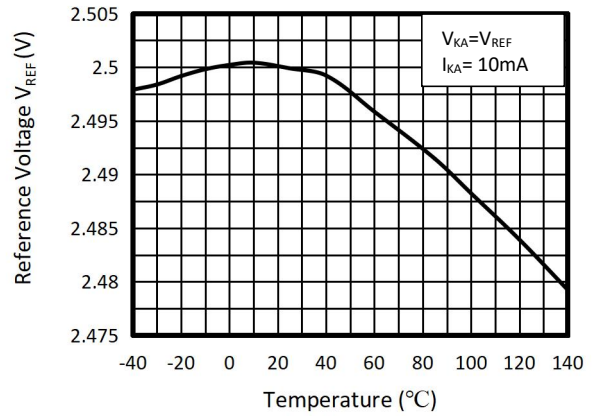

Figure 11. Reference Voltage vs Ambient Temperature

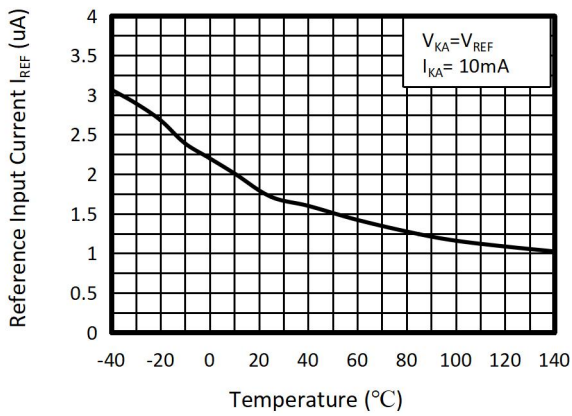
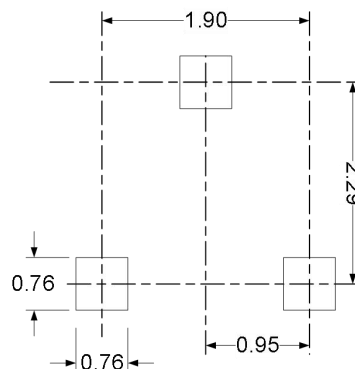
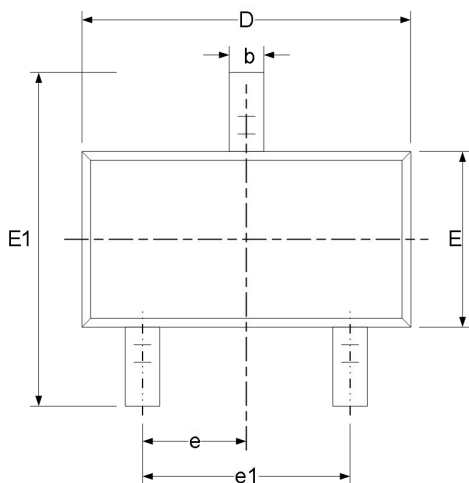

Figure 12. Reference Input Current vs Ambient Temperature

9 Package Outline Dimensions

SOT23⁽³⁾



RECOMMENDED LAND PATTERN (Unit: mm)

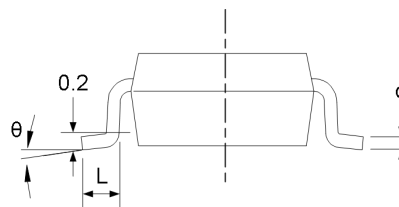
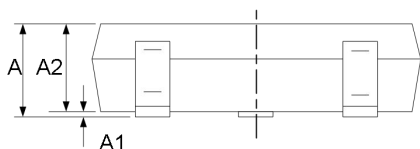

Symbol	Dimensions In Millimeters		Dimensions In Inches	
	Min	Max	Min	Max
A ⁽¹⁾	0.900	1.150	0.035	0.045
A1	0.000	0.100	0.000	0.004
A2	0.900	1.050	0.035	0.041
b	0.300	0.500	0.012	0.020
c	0.080	0.150	0.003	0.006
D ⁽¹⁾	2.800	3.000	0.110	0.118
E ⁽¹⁾	1.200	1.400	0.047	0.055
E1	2.250	2.550	0.089	0.100
e	0.950 (BSC) ⁽²⁾		0.037 (BSC) ⁽²⁾	
e1	1.800	2.000	0.071	0.079
L	0.300	0.500	0.012	0.020
theta	0°	8°	0°	8°

NOTE:

1. Plastic or metal protrusions of 0.15mm maximum per side are not included.
2. BSC (Basic Spacing between Centers), "Basic" spacing is nominal.
3. This drawing is subject to change without notice.

10 Tape and Reel Information

REEL DIMENSIONS

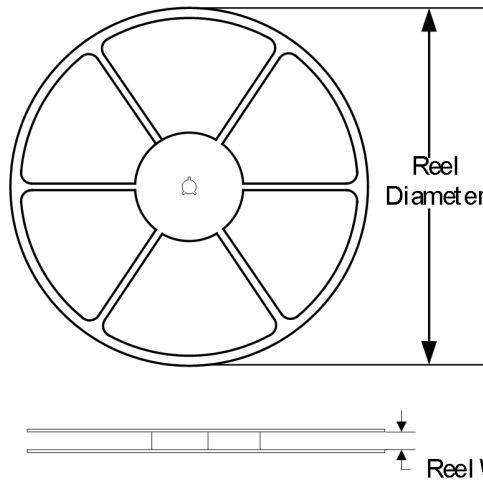

TAPE DIMENSION

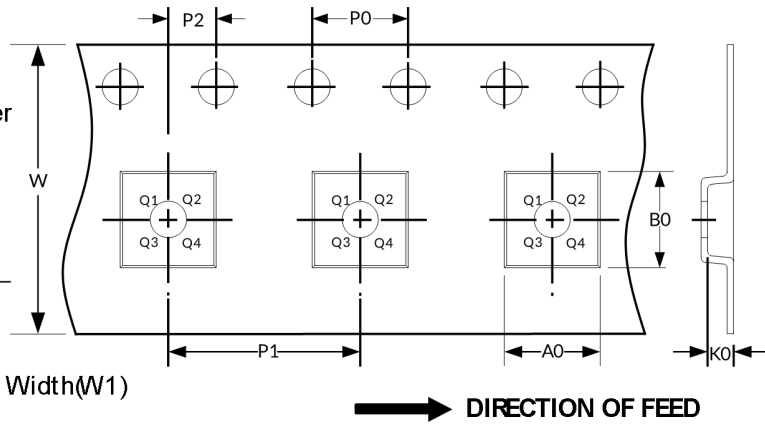

NOTE: The picture is only for reference. Please make the object as the standard.

KEY PARAMETER LIST OF TAPE AND REEL

Package Type	Reel Diameter	Reel Width (mm)	A0 (mm)	B0 (mm)	K0 (mm)	P0 (mm)	P1 (mm)	P2 (mm)	W (mm)	Pin1 Quadrant
SOT23	7"	9.5	3.15	2.77	1.22	4.0	4.0	2.0	8.0	Q3

NOTE:

1. All dimensions are nominal.
2. Plastic or metal protrusions of 0.15mm maximum per side are not included.

IMPORTANT NOTICE AND DISCLAIMER

Z-Micro will accurately and reliably provide technical and reliability data (including data sheets), design resources (including reference designs), application or other design advice, WEB tools, safety information and other resources, without warranty of any defect, and will not make any express or implied warranty, including but not limited to the warranty of merchantability Implied warranty that it is suitable for a specific purpose or does not infringe the intellectual property rights of any third party.

These resources are intended for skilled developers designing with Z-Micro products You will be solely responsible for: (1) Selecting the appropriate products for your application; (2) Designing, validating and testing your application; (3) Ensuring your application meets applicable standards and any other safety, security or other requirements; (4) Z-Micro and the Z-Micro logo are registered trademarks of Z-Micro. All trademarks are the property of their respective owners; (5) For change details, review the revision history included in any revised document. The resources are subject to change without notice. Our company will not be liable for the use of this product and the infringement of patents or third-party intellectual property rights due to its use.