

Low-Noise, Very Low Drift, Precision Voltage Reference

1 Features

- Qualified for Automotive Applications
- AEC-Q100 Qualified with the Grade 1
- Low Temperature Drift: 10 ppm/°C(Max)
- High Accuracy: 0.05% Maximum
- Low Noise: $8\mu\text{V}_{\text{PP}}/\text{V}$
- Low I_{Q} : 150 μA (Typical)
- Operating Temperature Range: -40°C to +125°C
- High Output Current: $\pm 10\text{ mA}$
- Micro SIZE PACKAGES: SOT23-6

2 Applications

- Precision Data Acquisition Systems
- Semiconductor Test Equipment
- Medical Instrumentation
- Industrial Process Controls
- Pressure and Temperature Transmitters
- Lab and Field Instrumentation

3 Descriptions

The ZMB34XX-Q1 is a family of low-noise, low-drift, very high precision voltage references. These references are capable of both sinking and sourcing current, and have excellent line and load regulation.

Excellent temperature drift (10ppm/°C) and high accuracy (0.05%) are achieved using proprietary design techniques with 150uA(typical) quiescent current. These features, combined with low noise, make the ZMB34XX-Q1 family ideal for use in high-precision data acquisition systems.

The ZMB34XX-Q1 is available in Green SOT23-6 packages. It operates over an ambient temperature range of -40°C to +125°C.

Device Information (1)

PART NUMBER	PACKAGE	BODY SIZE(NOM)
ZMB34XX-Q1	SOT23-6(6)	1.60mm×2.92mm

(1) For all available packages, see the orderable addendum at the end of the data sheet.

4 Typical Application

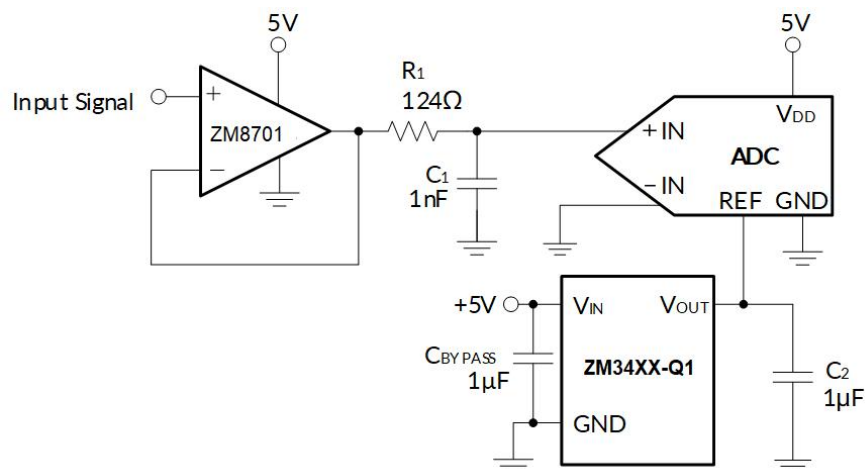

Table of Contents

1 Features	1
2 Applications	1
3 Descriptions	1
4 Typical Application	1
5 Revision History	3
6 Package/Ordering Information	4
7 Pin configuration and Functions	5
Pin Description	5
8 Specifications	6
8.1 Absolute Maximum Ratings	6
8.2 ESD Ratings	6
8.3 Recommended Operating Conditions	6
8.4 Electrical Characteristics	7
8.5 Typical Characteristics	9
9 Detailed Description	12
9.1 Overview	12
9.2 Functional Block Diagram	12
10 Feature Description	13
10.1 Temperature Drift	13
10.2 Thermal Hysteresis	13
10.3 Noise Performance	13
10.4 Long-Term Stability	13
11 Device Functional Modes	14
11.1 Basic Connections	14
11.2 Supply Voltage	14
11.3 Negative Reference Voltage	14
12 Layout	15
12.1 Layout Guidelines	15
12.2 Layout Example	15
12.3 Power Dissipation	15
13 Package Outline Dimensions	16
14 Tape and Reel Information	17

5 Revision History

Note: Page numbers for previous revisions may differ from page numbers in the current version.

VERSION	Change Date	Change Item
A.1	2023/07/03	Preliminary version completed

6 package/Ordering Information ⁽¹⁾

Orderable Device	Package Type	Lead finish/Ball material ⁽²⁾	MSL Peak Temp ⁽³⁾	Op Temp(°C)	Device Marking ⁽⁴⁾	Package Qty
ZMB3412XH6-Q1	SOT23-6	NIPDAUAG	MSL1-260°- Unlimited	-40°C ~+125°C	3412	Tape and Reel,3000
ZMB3413XH6-Q1	SOT23-6	NIPDAUAG	MSL1-260°- Unlimited	-40°C ~+125°C	3413	Tape and Reel,3000
ZMB3418XH6-Q1	SOT23-6	NIPDAUAG	MSL1-260°- Unlimited	-40°C ~+125°C	3418	Tape and Reel,3000
ZMB3420XH6-Q1	SOT23-6	NIPDAUAG	MSL1-260°- Unlimited	-40°C ~+125°C	3420	Tape and Reel,3000
ZMB3425XH6-Q1	SOT23-6	NIPDAUAG	MSL1-260°- Unlimited	-40°C ~+125°C	3425	Tape and Reel,3000
ZMB3430XH6-Q1	SOT23-6	NIPDAUAG	MSL1-260°- Unlimited	-40°C ~+125°C	3430	Tape and Reel,3000
ZMB3433XH6-Q1	SOT23-6	NIPDAUAG	MSL1-260°- Unlimited	-40°C ~+125°C	3433	Tape and Reel,3000
ZMB3440XH6-Q1	SOT23-6	NIPDAUAG	MSL1-260°- Unlimited	-40°C ~+125°C	3440	Tape and Reel,3000
ZMB3445XH6-Q1	SOT23-6	NIPDAUAG	MSL1-260°- Unlimited	-40°C ~+125°C	3445	Tape and Reel,3000
ZMB3450XH6-Q1	SOT23-6	NIPDAUAG	MSL1-260°- Unlimited	-40°C ~+125°C	3450	Tape and Reel,3000

NOTE:

- (1) This information is the most current data available for the designated devices. This data is subject to change without notice and revision of this document. For browser-based versions of this data sheet, refer to the right-hand navigation.
- (2) Lead finish/Ball material. Orderable Devices may have multiple material finish options. Finish options are separated by a vertical ruled line. Lead finish/Ball material values may wrap to two lines if the finish value exceeds the maximum column width.
- (3) MSL Peak Temp. The Moisture Sensitivity Level rating according to the JEDEC industry standard classifications, and peak solder temperature.
- (4) There may be additional marking, which relates to the lot trace code information (data code and vendor code), the logo or the environmental category on the device.

7 Pin configuration and Functions (Top View)

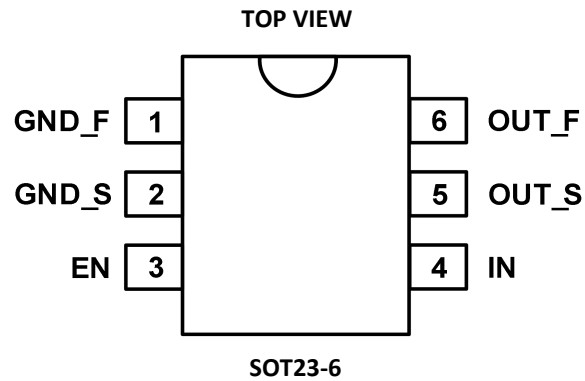

Pin Description

PIN	NAME	I/O TYPE ⁽¹⁾	FUNCTION
SOT23-6			
1	GND_F	G	Ground force connection.
2	GND_S	G	Ground sense connection.
3	EN	I	Enable connection. Enables or disables the device.
4	IN	P	Input supply voltage connection.
5	OUT_S	I	Reference voltage output sense connection.
6	OUT_F	O	Reference voltage output force connection.

(1) I = Input, O = Output, P=Power.

8 specifications

8.1 Absolute Maximum Ratings

over operating free-air temperature range (unless otherwise noted) ⁽¹⁾⁽²⁾

SYMBOL	PARAMETER	MIN	MAX	UNIT	
IN	Input voltage	-0.3	13	V	
EN		-0.3	IN+0.3	V	
V _{OUT}	Output voltage	-0.3	5.5	V	
I _{SC}	Output short circuit current		30	mA	
θ _{JA}	Package thermal impedance ⁽³⁾	SOT23-6		230	°C/W
T _A	Operating temperature	-40	+125	°C	
T _J	Junction temperature ⁽⁴⁾	-40	150		
T _{stg}	Storage temperature	-65	150		

- (1) Stresses beyond those listed under Absolute Maximum Ratings may cause permanent damage to the device. These are stress ratings only, and functional operation of the device at these or any other conditions beyond those indicated under Recommended Operating Conditions is not implied. Exposure to absolute-maximum-rated conditions for extended periods may affect device reliability.
- (2) All voltages are with respect to the GND pin.
- (3) The package thermal impedance is calculated in accordance with JESD-51.
- (4) The maximum power dissipation is a function of T_{J(MAX)}, R_{θJA}, and T_A. The maximum allowable power dissipation at any ambient temperature is P_D = (T_{J(MAX)} - T_A) / R_{θJA}. All numbers apply for packages soldered directly onto a PCB.

8.2 ESD Ratings

The following ESD information is provided for handling of ESD-sensitive devices in an ESD protected area only.

		VALUE	UNIT	
V _(ESD)	Electrostatic discharge	Human-Body Model (HBM), per AEC Q100-002 ⁽¹⁾	±2000	V
		Charged-Device Model (CDM), per AEC Q100-011	±1500	V
		Latch-Up (LU), per AEC Q100-004	±200	mA

- (1) AEC Q100-002 indicates that HBM stressing shall be in accordance with the ANSI/ESDA/JEDEC JS-001 specification.



ESD SENSITIVITY CAUTION

ESD damage can range from subtle performance degradation to complete device failure. Precision integrated circuits may be more susceptible to damage because very small parametric changes could cause the device not to meet its published specifications.

8.3 Recommended Operating Conditions

over operating free-air temperature range (unless otherwise noted)

SYMBOL	PARAMETER	MIN	MAX	UNIT
IN	Input voltage	V _{OUT} +0.5 ⁽¹⁾	12	V
EN	Enable Voltage	0	IN	V
I _{Load}	Load current	-10	10	mA
T _A	Operating Temperature	-40	125	°C

- (1) Minimum supply voltage for the ZMB34XX-Q1 is 4 V.

8.4 Electrical Characteristics

At $V_{IN} = 5V$, $C_{OUT} = 10 \mu F$, $C_{IN} = 1 \mu F$, $I_L = 0 \text{ mA}$, Typical specifications at $T_A = 25^\circ\text{C}$, unless otherwise noted.

PARAMETER		TEST CONDITIONS	MIN	TYP	MAX	UNIT
Output Voltage	V_{OUT}	ZMB3412-Q1		1.2		V
		ZMB3413-Q1		1.25		
		ZMB3418-Q1		1.8		
		ZMB3420-Q1		2.048		
		ZMB3425-Q1		2.5		
		ZMB3430-Q1		3.0		
		ZMB3433-Q1		3.3		
		ZMB3440-Q1		4.096		
		ZMB3445-Q1		4.5		
		ZMB3450-Q1		5.0		
Initial Accuracy	V_{OERR}	All voltage options ⁽¹⁾	-0.05		0.05	%
Temperature Coefficient	TC	$T_A = -40^\circ\text{C}$ to $+125^\circ\text{C}$		5	10	ppm/ $^\circ\text{C}$
Output Voltage Noise	e_n	$f = 0.1\text{Hz}$ to 10Hz		8		$\mu\text{V}_{PP}/\text{V}$
Line Regulation	dV_{OUT}/dV_{IN}	$V_{IN} = (V_{OUT} + 0.5)$ to 12 V		1	5	ppm/V
		$V_{IN} = (V_{OUT} + 0.5)$ to 12 V , $T_A = -40^\circ\text{C}$ to $+125^\circ\text{C}$			8	
Load Regulation	dV_{OUT}/dI_{LOAD}	$I_L = 0 \text{ mA}$ to 10 mA , $V_{IN} = V_{OUT} + 0.5 \text{ V}$ ⁽²⁾		1.5	5	ppm/mA
		$I_L = 0 \text{ mA}$ to 10 mA , $V_{IN} = V_{OUT} + 0.5 \text{ V}$, $T_A = -40^\circ\text{C}$ to $+125^\circ\text{C}$ ⁽²⁾			8	
		$I_L = 0 \text{ mA}$ to -10 mA , $V_{IN} = V_{OUT} + 0.5 \text{ V}$ ⁽²⁾		2.5	8	
		$I_L = 0 \text{ mA}$ to -10 mA , $V_{IN} = V_{OUT} + 0.5 \text{ V}$, $T_A = -40^\circ\text{C}$ to $+125^\circ\text{C}$ ⁽²⁾			25	
Short-Circuit Current	I_{SC}	Sourcing		23		mA
		Sinking		25		
Long-Term Stability		0 to 1000h @30°C		47		ppm
		1000h to 2000h @30°C		44		
		0 to 2000h @30°C		66		
Thermal Hysteresis		25°C , -40°C , 125°C , 25°C Cycle1		75		ppm
Turn on Settling Time	t_{ON}	To 0.1% with $C_L = 10\mu\text{F}$		2		ms
Capacitive Load	C_L		1		10	μF
Voltage	V_{IN}	$I_{LOAD} = 0$, $T_A = -40^\circ\text{C}$ to $+125^\circ\text{C}$	$V_{OUT} + 0.5$ ⁽¹⁾		12	V
Quiescent Current	I_Q	Active mode, $I_{LOAD} = 0$, $T_A = 25^\circ\text{C}$		150	200	μA
		Active mode, $I_{LOAD} = 0$, $T_A = -40^\circ\text{C}$ to $+125^\circ\text{C}$			230	
		Shutdown mode, $T_A = 25^\circ\text{C}$		4	10	μA
		Shutdown mode, $T_A = -40^\circ\text{C}$ to $+125^\circ\text{C}$			15	
ENABLE Pin Voltage		Voltage reference in active mode ($EN = 1$), $T_A = -40^\circ\text{C}$ to $+125^\circ\text{C}$	1.5			V
		Voltage reference in shutdown mode ($EN = 0$), $T_A = -40^\circ\text{C}$ to $+125^\circ\text{C}$			0.5	

ENABLE Pin Leakage Current	I_{EN}	$V_{EN} = V_{IN} = 12V, T_A = 25^\circ C$		1.5	3	μA
		$V_{EN} = V_{IN} = 12V, T_A = -40^\circ C \text{ to } +125^\circ C$			4	

NOTE:

- (1) Minimum supply voltage for the ZMB34XX-Q1 is 4 V.
- (2) Typical value of load regulation reflects measurements using force and sense contacts;

8.5 Typical Characteristics

NOTE: The graphs and tables provided following this note are a statistical summary based on a limited number of samples and are provided for informational purposes only.

At $T_A = 25^\circ\text{C}$, $V_{IN} = V_{EN} = 12\text{ V}$, $I_L = 0\text{ mA}$, $C_L = 10\text{ }\mu\text{F}$, $C_{IN} = 1\text{ }\mu\text{F}$ (unless otherwise noted).

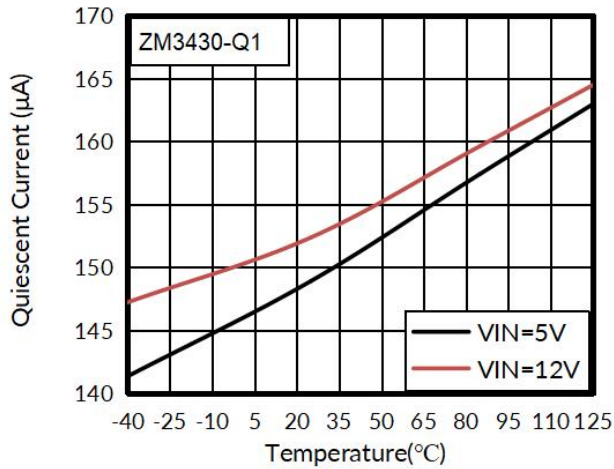

Figure 1. I_Q vs Temperature over V_{IN}

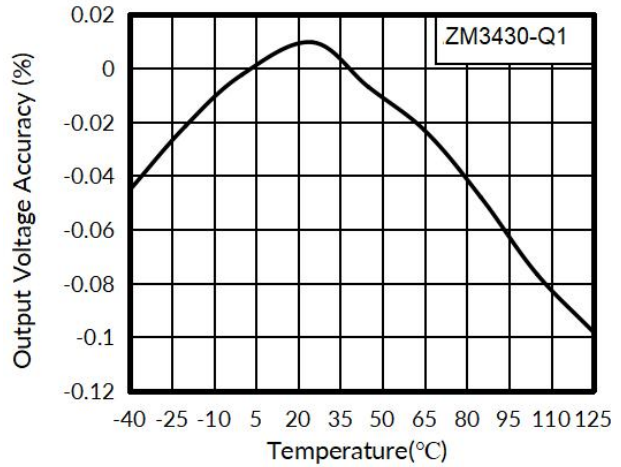

Figure 2. Output Voltage Accuracy vs Temperature

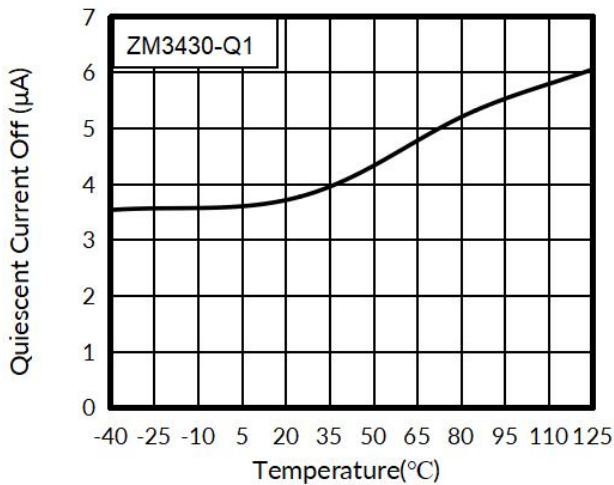

Figure 3. Quiescent Current Shutdown Mode

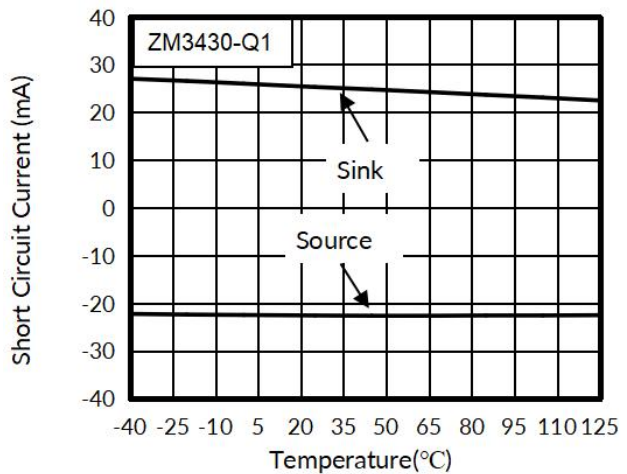

Figure 4. Short Circuit Current vs Temperature

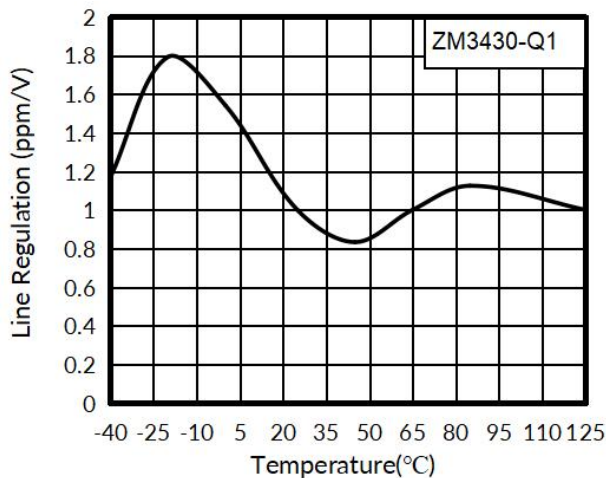

Figure 5. Line Regulation

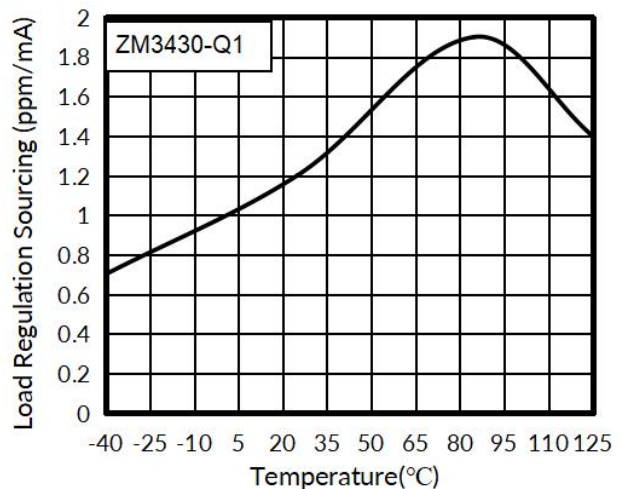

Figure 6. Load Regulation Sourcing

Typical Characteristics

NOTE: The graphs and tables provided following this note are a statistical summary based on a limited number of samples and are provided for informational purposes only.

At $T_A = 25^\circ\text{C}$, $V_{IN} = V_{EN} = 12\text{ V}$, $I_L = 0\text{ mA}$, $C_L = 10\ \mu\text{F}$, $C_{IN} = 1\ \mu\text{F}$ (unless otherwise noted).

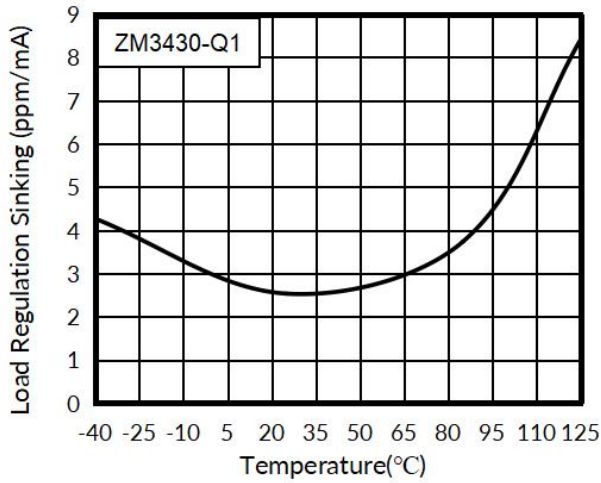

Figure 7. Load Regulation Sinking

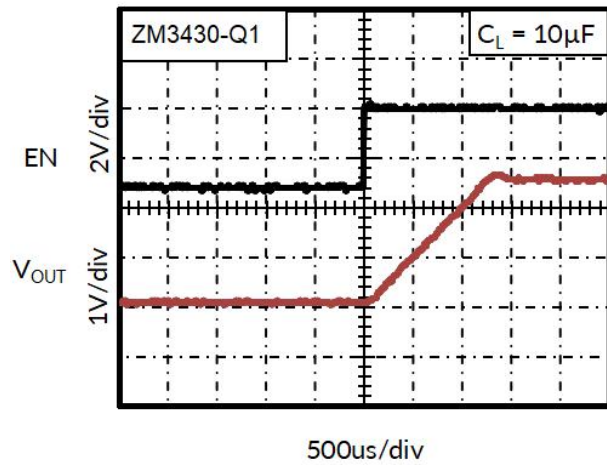

Figure 8. Turn on Time (Enable)

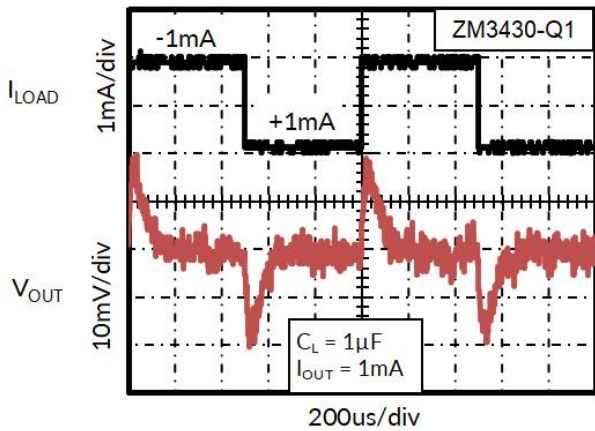

Figure 9. Load Transient

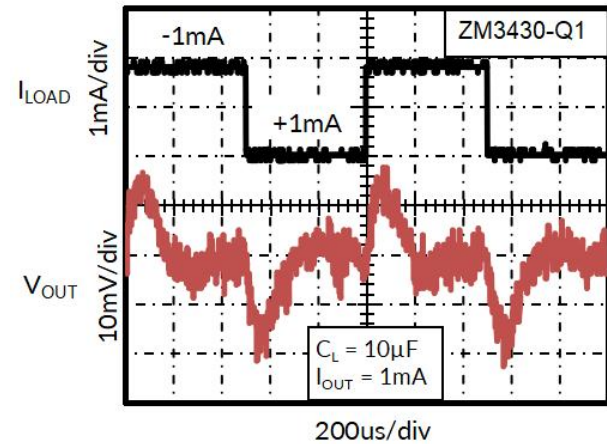

Figure 10. Load Transient

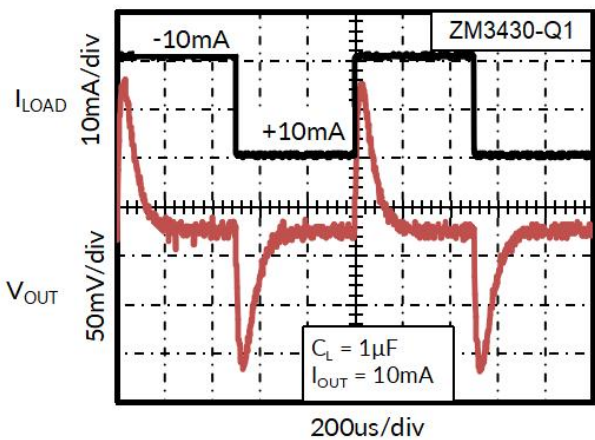

Figure 11. Load Transient

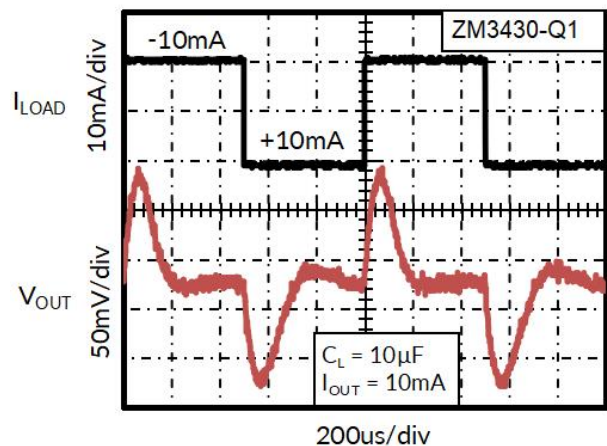

Figure 12. Load Transient

Typical Characteristics

NOTE: The graphs and tables provided following this note are a statistical summary based on a limited number of samples and are provided for informational purposes only.

At $T_A = 25^\circ\text{C}$, $V_{IN} = V_{EN} = 12\text{ V}$, $I_L = 0\text{ mA}$, $C_L = 10\ \mu\text{F}$, $C_{IN} = 1\ \mu\text{F}$ (unless otherwise noted).

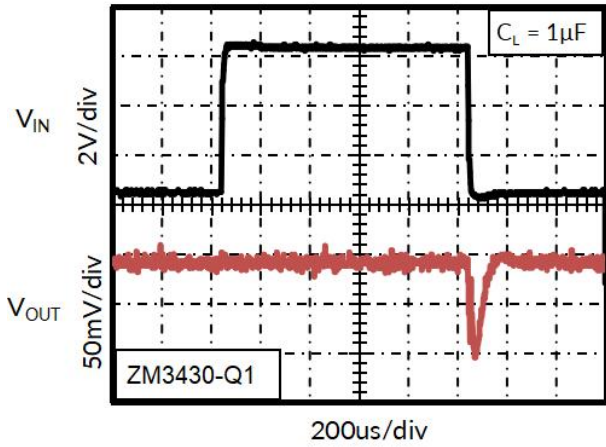

Figure 13. Line Transient

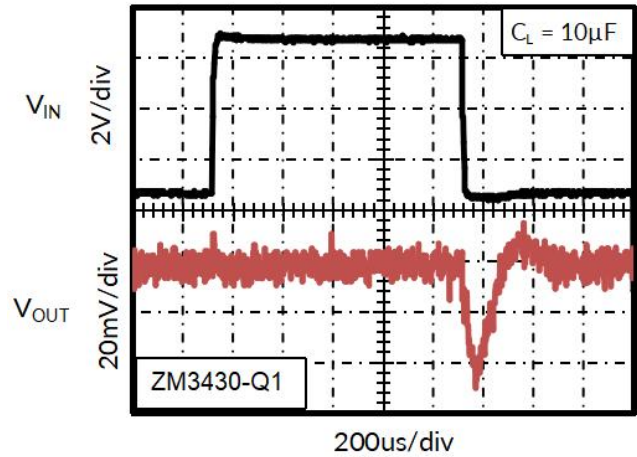

Figure 14. Line Transient

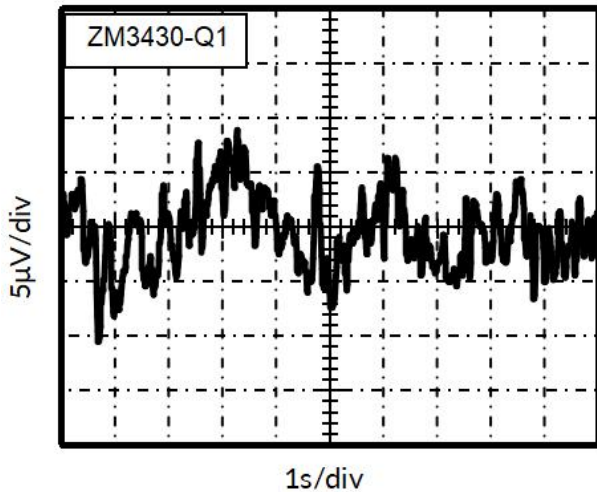

Figure 15. 0.1-Hz to 10-Hz Noise (VOUT)

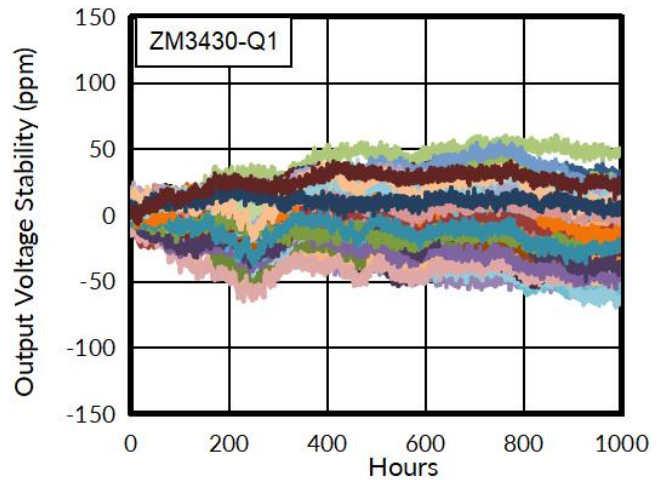

Figure 16. Long - Term Stability (First 1000 hours)

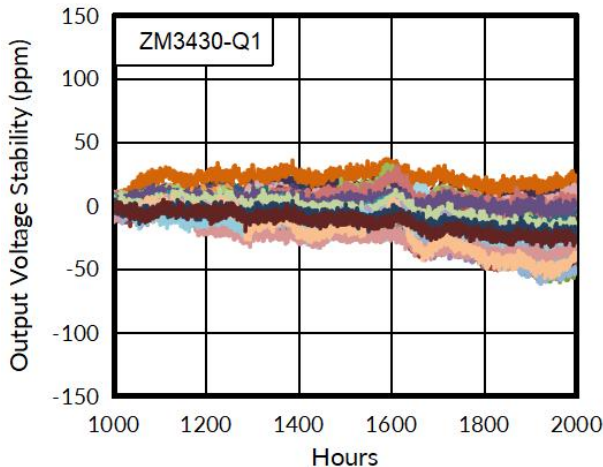

Figure 17. Long - Term Stability (Second 1000 hours)

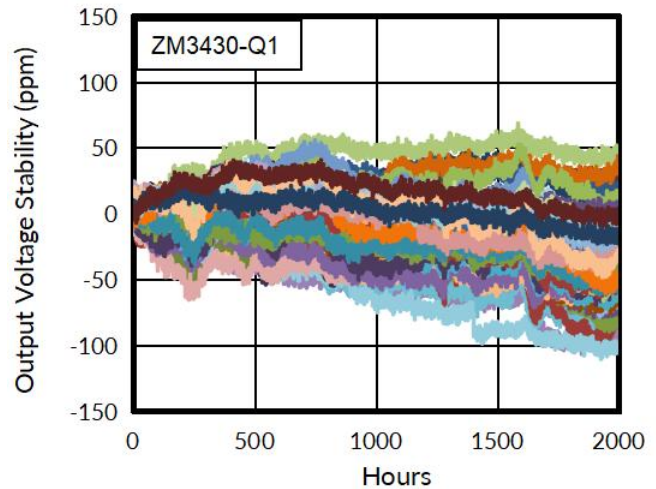

Figure 18. Long - Term Stability (First 2000 hours)

9 Detailed Description

9.1 Overview

The ZMB34XX-Q1 is family of precision bandgap voltage references that are specifically designed for excellent initial voltage accuracy and drift. See the Functional Block Diagram for a simplified block diagram of the ZMB34XX-Q1.

9.2 Functional Block Diagram

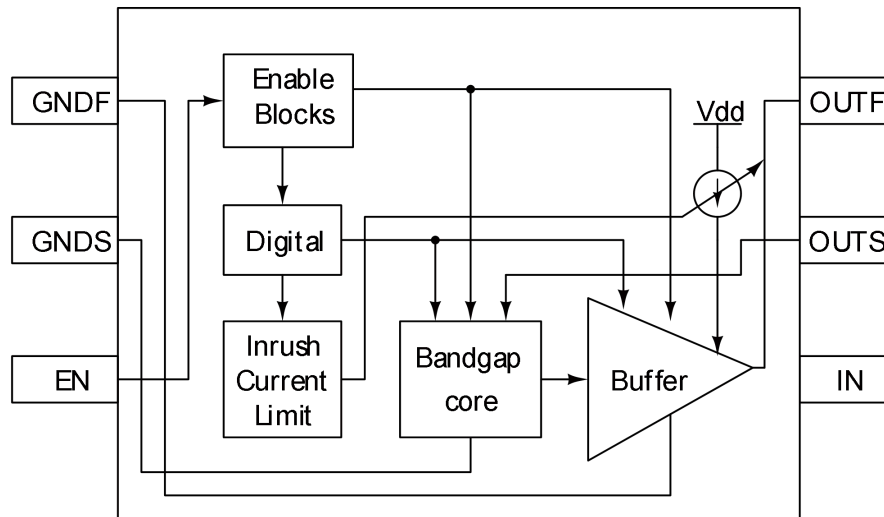

10 Feature Description

10.1 Temperature Drift

The ZMB34XX-Q1 is designed for minimal drift error, which is defined as the change in output voltage over temperature. The drift is calculated using the box method, as described in Equation 1.

$$\text{Drift} = \left(\frac{V_{\text{OUTMAX}} - V_{\text{OUTMIN}}}{V_{\text{OUT}} \times \text{Temp Range}} \right) \times 10^6 (\text{ppm}) \quad (1)$$

The ZMB34XX-Q1 features a maximum drift coefficient of 10 ppm/°C.

10.2 Thermal Hysteresis

Thermal hysteresis for the ZMB34XX-Q1 is defined as the change in output voltage after operating the device at 25°C, cycling the device through the specified temperature range, and returning to 25°C. Thermal hysteresis can be expressed as Equation 2:

$$V_{\text{HYST}} = \left(\frac{|V_{\text{PRE}} - V_{\text{POST}}|}{V_{\text{NOM}}} \right) \times 10^6 (\text{ppm})$$

where

- V_{HYST} = thermal hysteresis (in units of ppm).
- V_{NOM} = the specified output voltage.
- V_{PRE} = output voltage measured at 25°C pretemperature cycling.
- V_{POST} = output voltage measured after the device has been cycled from 25°C through the specified temperature range of -40°C to 125°C and returned to 25°C. (2)

10.3 Noise Performance

Typical 0.1Hz to 10Hz voltage noise for each member of the ZMB34XX-Q1 family is specified in the Electrical Characteristics table. The noise voltage increases with output voltage and operating temperature. Additional filtering can be used to improve output noise levels, although take care to ensure the output impedance does not degrade performance.

10.4 Long-Term Stability

Due to aging and environmental effects, all semiconductor devices experience physical changes of the semiconductor die and the packaging material over time. These changes and the associated package stress on the die cause the output voltage in precision voltage references to deviate over time. The value of such change is specified on the datasheet by a parameter called the Long-term stability (also known as the Long-Term Drift (LTD)). Equation 3 shows how LTD is calculated. Note that the LTD value will be positive if the output voltage drifts higher over time, negative if the voltage drifts lower over time.

$$\text{LTD}(\text{ppm})|_{t=n} = \frac{(V_{\text{OUT}}|_{t=0} - V_{\text{OUT}}|_{t=n})}{V_{\text{OUT}}|_{t=0}} \times 10^6$$

where

- $\text{LTD}(\text{ppm})|_{t=n}$ = Long-term stability (in units of ppm).
- $V_{\text{OUT}}|_{t=0}$ = Output voltage at time = 0 hr.
- $V_{\text{OUT}}|_{t=n}$ = Output voltage at time = n hr. (3)

11 Device Functional Modes

11.1 Basic Connections

Figure 19 shows the typical connections for the ZMB34XX-Q1. Z-Micro recommends a supply bypass capacitor ranging from 1 μ F to 10 μ F. A minimum 1 μ F output capacitor (C_L) must be connected from V_{OUT} to GND.

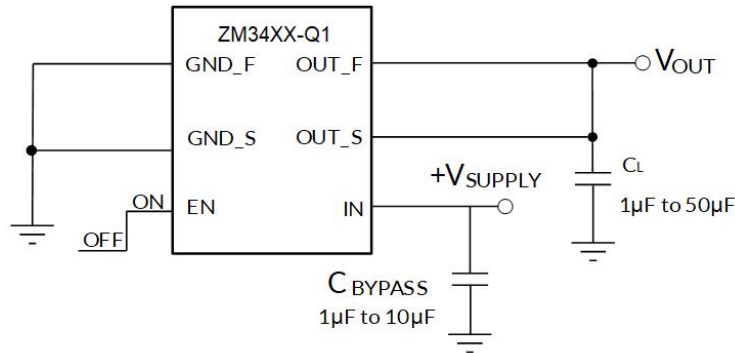

Figure 19. Basic Connections

11.2 Supply Voltage

The ZMB34XX-Q1 family of voltage references features extremely low dropout voltage. With the exception of the $V_{OUT} < 4.0V$, which has a minimum supply requirement of 4.0 V, these references can be operated with a supply of 500 mV more than the output voltage in an unloaded condition.

11.3 Negative Reference Voltage

For applications requiring a negative and positive reference voltage, the ZMB34XX-Q1 and ZM8651 can be used to provide a dual-supply reference from a 5V supply. Figure 20 shows the ZMB3430-Q1 used to provide a 3.0V supply reference voltage. The low drift performance of the ZMB34XX-Q1 complements the low offset voltage and zero drift of the ZM8651 to provide an accurate solution for split-supply applications. Take care to match the temperature coefficients of R_1 and R_2 .

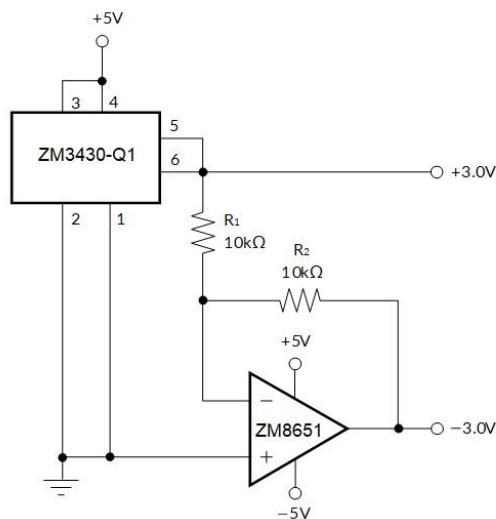

Figure 20. The ZMB3430-Q1 and ZM8651 Create Positive and Negative Reference Voltages

12 Layout

12.1 Layout Guidelines

- Place the power-supply bypass capacitor as closely as possible to the supply and ground pins. The recommended value of this bypass capacitor is from 1 μF to 10 μF . If necessary, additional decoupling capacitance can be added to compensate for noisy or high-impedance power supplies.
- Place a 1 μF noise filtering capacitor between the NR pin and ground.
- The output must be decoupled with a 1 μF to 50 μF capacitor. A resistor in series with the output capacitor is optional. For better noise performance, the recommended ESR on the output capacitor is from 1 Ω to 1.5 Ω .
- A high-frequency, 1 μF capacitor can be added in parallel between the output and ground to filter noise and help with switching loads as data converters.

12.2 Layout Example

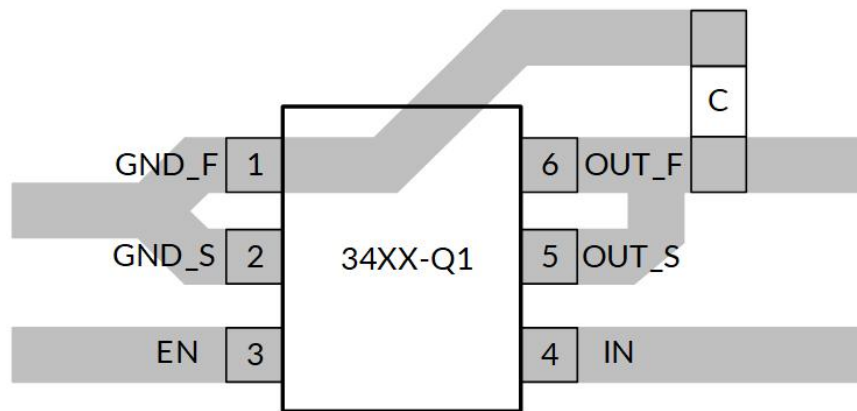

Figure 21. Layout Example

12.3 Power Dissipation

The ZMB34XX-Q1 family is specified to deliver current loads of ± 10 mA over the specified input voltage range. The temperature of the device increases according to Equation 4:

$$T_J = T_A + P_D \times \theta_{JA}$$

where

- T_J = Junction temperature ($^{\circ}\text{C}$)
- T_A = Ambient temperature ($^{\circ}\text{C}$)
- P_D = Power dissipated (W)
- θ_{JA} = Junction-to-ambient thermal resistance ($^{\circ}\text{C}/\text{W}$)

(4)

The ZMB34XX-Q1 junction temperature must not exceed the absolute maximum rating of 150 $^{\circ}\text{C}$.

13 package Outline Dimensions SOT23-6⁽³⁾

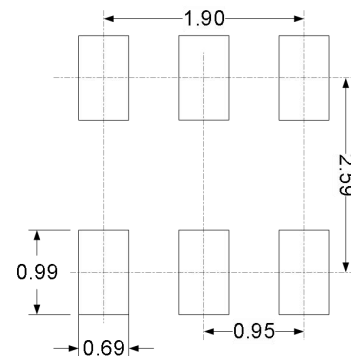
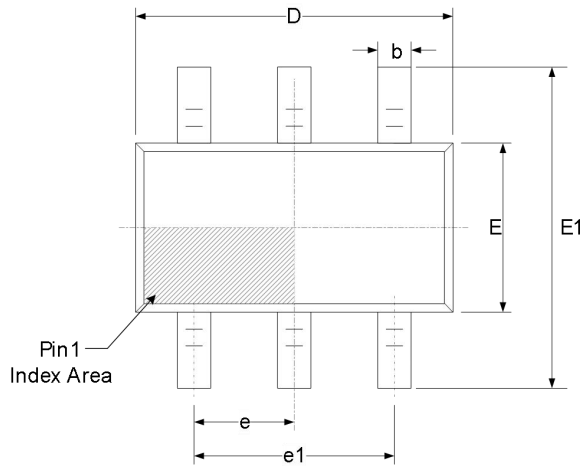

RECOMMENDED LAND PATTERN (Unit: mm)

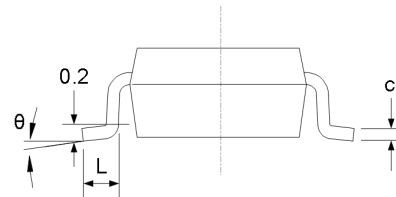
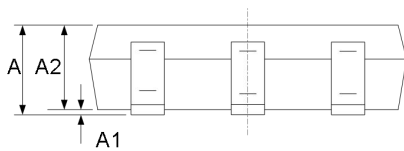

Symbol	Dimensions In Millimeters		Dimensions In Inches	
	Min	Max	Min	Max
A ⁽¹⁾	1.050	1.250	0.041	0.049
A1	0.000	0.100	0.000	0.004
A2	1.050	1.150	0.041	0.045
b	0.300	0.500	0.012	0.020
c	0.100	0.200	0.004	0.008
D ⁽¹⁾	2.820	3.020	0.111	0.119
E ⁽¹⁾	1.500	1.700	0.059	0.067
E1	2.650	2.950	0.104	0.116
e	0.950(BSC) ⁽²⁾		0.037(BSC) ⁽²⁾	
e1	1.800	2.000	0.071	0.079
L	0.300	0.600	0.012	0.024
θ	0°	8°	0°	8°

NOTE:

1. Plastic or metal protrusions of 0.15mm maximum per side are not included.
2. BSC (Basic Spacing between Centers), "Basic" spacing is nominal.
3. This drawing is subject to change without notice.

14 Tape and Reel Information

REEL DIMENSIONS

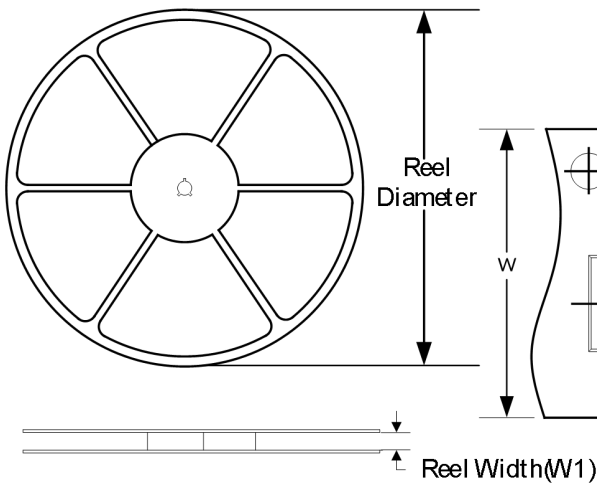

TAPE DIMENSION

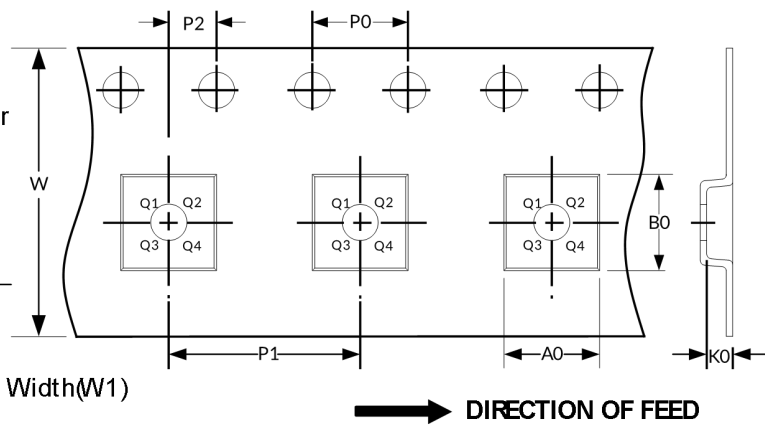

NOTE: The picture is only for reference. Please make the object as the standard.

KEY PARAMETER LIST OF TAPE AND REEL

Package Type	Reel Diameter	Reel Width (mm)	A0 (mm)	B0 (mm)	K0 (mm)	P0 (mm)	P1 (mm)	P2 (mm)	W (mm)	Pin1 Quadrant
SOT23-6	7"	9.5	3.17	3.23	1.37	4.0	4.0	2.0	8.0	Q3

NOTE:

1. All dimensions are nominal.
2. Plastic or metal protrusions of 0.15mm maximum per side are not included.

IMPORTANT NOTICE AND DISCLAIMER

Z-Micro will accurately and reliably provide technical and reliability data (including data sheets), design resources (including reference designs), application or other design advice, WEB tools, safety information and other resources, without warranty of any defect, and will not make any express or implied warranty, including but not limited to the warranty of merchantability Implied warranty that it is suitable for a specific purpose or does not infringe the intellectual property rights of any third party.

These resources are intended for skilled developers designing with Z-Micro products You will be solely responsible for: (1) Selecting the appropriate products for your application; (2) Designing, validating and testing your application; (3) Ensuring your application meets applicable standards and any other safety, security or other requirements; (4) Z-Micro and the Z-Micro logo are registered trademarks of Z-Micro. All trademarks are the property of their respective owners; (5) For change details, review the revision history included in any revised document. The resources are subject to change without notice. Our company will not be liable for the use of this product and the infringement of patents or third-party intellectual property rights due to its use.